

LIUGONG
AUSTRALIA

2025G-C

3-SERIES FORKLIFT

ENGINE
PSI 4G64 LPG 2.4L

RATED POWER
62 hp

CAPACITY
2,267kg



SPECIFICATIONS

GENERAL

Power type	2	LPG
Base capacity	3	2,267 kg
Load center	4	24 in

WEIGHTS

Service weight	5	unloaded	3,692.2 kg
Axle load	6	loaded / unloaded, front	5,382.8 / 1,292.3 kg
	7	loaded / unloaded, rear	804.2 / 2,400 kg

TIRES

Tire type	8	Cushion	
Wheels	9	front / rear	2 / 2
Wheelbase	10	1,485.9 mm	
Tire size	11	front	21x7-15 PR
	12	rear	16x5x10-1/2 PR
Tread width	13	front / rear	889 / 919.5 mm

MAST

Max. fork height	14	with std 2-stage mast	2,999.7 mm
Free lift	15	with std 2-stage mast	139.7 mm
Height, upright lowered	16	with std 2-stage mast	2,131.1 mm
Height, upright extended	17	with std 2-stage mast	4,097 mm
Mast tilt, fwd, back	18	with std 2-stage mast	6° / 12°
Carriage	19	width	919.5 mm
Fork spread	20	minimum / maximum	220 / 881.4 mm
Fork dimensions	21	T x W x L (mm)	40.6 x 99.1 x 1,069.3

CHASSIS

Length to fork face	22	with std 2-stage mast	2,390.1 mm
Overall width	23	1,099.8 mm	
Overhead guard height	24	2,120.9 mm	
Turning radius	25	minimum outside	1,950.7 mm
Fork overhang	26	with std 2-stage mast	424.2 mm
Right angle stack	27	add load length and clearance	3,650 mm
Ground clearance	28	minimum loaded	88.9 mm
	29	center of wheelbase	139.7 mm

Performance

Travel speed	30	loaded / unloaded	17 / 17.5 km/h
Lift speed	31	loaded / unloaded	0.6 / 0.65m/s
Lower speed	32	loaded / unloaded	0.5 / 0.5 m/s
Max. drawbar pull	33	loaded	1,995.8 kg
Max. gradeability	34	loaded / unloaded	35 / 22 %

Systems

Brakes	35	service	Foot / hyd
	36	parking	Hand / mech
Engine	37	manufacturer	PSI
	38	model	4G64
	39	emission compliance	EPA 4F
	40	cylinders	4
	41	displacement	2.4 liter
	42	rated power	46kw / 2,700 (rpm)
	43	max. torque	168Nm / 1600 (rpm)

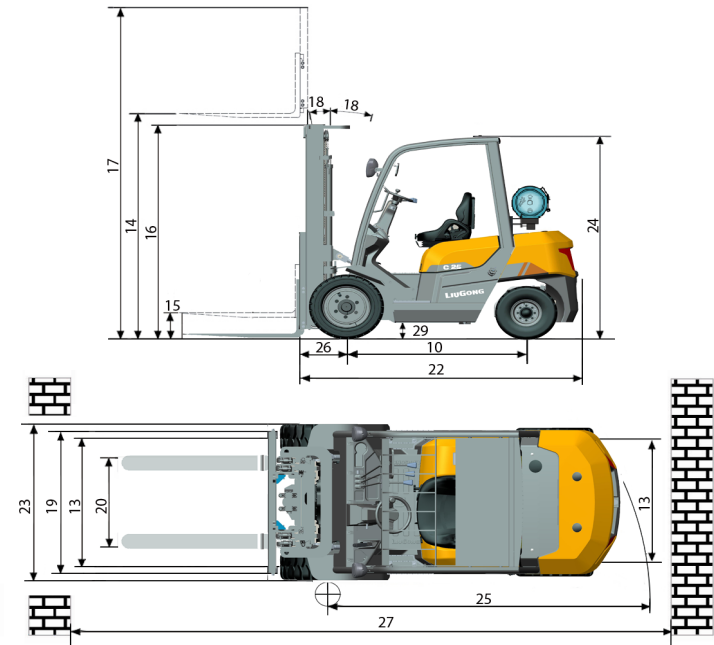

LGNA-SS-2025G-3-20211011-ENG-US

Specifications and designs are subject to change without notice.
Machines shown may include optional equipment.

LiuGong Machinery Australia Pty. Ltd.
22 Agosta Drive
Laverton North Victoria
3026 AUS

www.liugongna.com.au T: +61 03 8539 7716