

LIUGONG
AUSTRALIA

2070H

3-SERIES FORK TRUCK

ENGINE
Cummins
(LPG or Dual Fuel)

RATED POWER
120.7 hp
(90 kW)

CAPACITY
15,432 lb
(7,000 kg)



SPECIFICATIONS

GENERAL

Model	CLG2070H		
Power type	1	Diesel Tier T4F	
Operator type	2	Sit-Down Rider	
Base capacity	3	@ rated load center	15,432 lb (7,000 kg)
Load center	4	24 in (600 mm)	

WEIGHTS

Service weight	5	unloaded	20,503 lb (9,300 kg)
Axle load	6	loaded/unloaded, front	31,879/8,377 lb (14,460/3,800 kg)
	7	loaded/unloaded, rear	4,056/12,125 lb (1,840/5,500 kg)

TIRES

Tire type	8	Pneumatic	
Wheels	9	front/rear	4/2
Wheelbase	10	88.6 in (2,250 mm)	
Tire size	11	front	8.25x15
	12	rear	8.25x15
Tread width	13	front/rear	58/68.1 in (1,474/1,730 mm)

MAST

Max. fork height	14	with std 2-stage mast	118.1 in (3,000 mm)
Free lift	15	with std 2-stage mast	8.3 in (210 mm)
Height, upright lowered	16	with std 2-stage mast	99.8 in (2,534 mm)
Height, upright extended	17	with std 2-stage mast	172.3 in (4,377 mm)
Mast tilt, fwd, back	18	with std 2-stage mast	6°/12°
Carriage	19	ISO Class	IV
		width	72.4 in (1,840 mm)
Fork spread	20	minimum/maximum	11.8/72.4 in (300/1,840 mm)
Fork dimensions	21	T x W x L	2.8 x 5.9 x 59.8 in (65 x 150 x 1520 mm)

CHASSIS

Length to fork face	22	with std 2-stage mast	143.7 in (3,650 mm)
Overall width	23	80.3 in (2,040 mm)	
Overhead guard height	24	97.4 in (2,475 mm)	
Turning radius	25	minimum outside	140.2 in (3,560 mm)
Fork overhang	26	with std 2-stage mast	23.3 in (592 mm)
Right angle stack	27	add load length and clearance	148.0 in (3,760 mm)
Ground clearance	28	minimum loaded	8.0 in (203 mm)
	29	center of wheelbase	9.8 in (250 mm)

PERFORMANCE

Model	CLG2070H		
Travel speed	30	loaded/unloaded	16.2/17.4 mph (26/28 km/h)
Lift speed	31	loaded/unloaded	76.8/98.4 fpm (0.39/0.5 m/s)
Lower speed	32	loaded/unloaded	98.4/78.7 fpm (0.5/0.4 m/s)
Max. drawbar pull	33	loaded	13,228 lb (6,000 kg)
Max. gradeability	34	loaded/unloaded	20%

SYSTEMS

Brakes	35	service	Foot/hyd
	36	parking	Hand/mech
	37	manufacturer	Cummins
	38	model	F3.8
	39	emission compliance	T4F/Tier V
Engine	40	cylinders	4
	41	displacement	3.8 liter
	42	rated power	120.7 hp (90 kW)
			2,200 rpm
	43	max. torque	369 lb/ft (500 N/m)
Transmission	44	type	Powershift
	45	speeds, fwd/rev	2/2
Hydraulic Pressure	46	system	2,828 psi (195 bar)
	47	attachment	2,103 psi (145 bar)

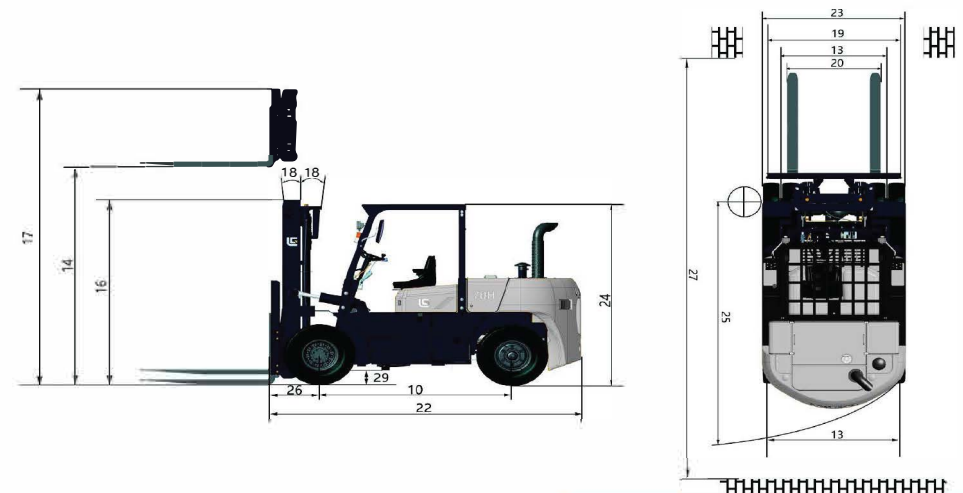

LGNA-SS-2070H-202304-ENG-US

Specifications and designs are subject to change without notice. Machines shown may include optional equipment.

LiuGong Machines Australia Pty. Ltd.
22 Agosta Drive
Laverton North Victoria
3026 AUS

www.liugong.com.au

T: +61 03 8539 7716